

TEACHER TRAINING IN ADULT & LIFELONG LEARNING : Indian Scenario---1.

- Teacher Training- most neglected area
- Profile of Institutions and Professionals
- Teaching & Training Scenario
- Lacunae in the system
- Recent Initiatives towards professionalization

TEACHER TRAINING IN ADULT & LIFELONG LEARNING :

Indian Scenario---2.

**India - Second Largest country in terms of Population (1028 Millions)
Third largest education system**

Formal Institutions ;

**Universities -358
Teacher Training colleges 2019**

Non Formal Institutions

**University Departments of Adult Continuing Education -82.
District Institute of Education and Training -577
Community Colleges -190
Community Polytechnics -669
Open Universities and Schools- 20**

**State Resource Centers in Adult Education -26
Institute of Peoples Education -221**



TEACHER TRAINING IN ADULT & LIFELONG LEARNING : Indian Scenario---3.

Teaching Profession has the largest number

- | | |
|--|----------------------|
| Teachers at different levels. | 5.5 million (approx) |
| ■ Teacher Educators | - 50,000 (approx) |
| ■ University Teachers in Adult Education | - 408 |
| ■ Trainers at Provincial level | - 104 |
| ■ Trainers at District level | - 884 |
| ■ Instructors (vocational training) | -12,000 (approx) |
| ■ Grassroots level trainers | - 4,00,000 (approx) |



TEACHER TRAINING IN ADULT & LIFELONG LEARNING : Indian Scenario---4.

Four Types of Organizations

- Universities/Colleges/Institutes
- Government Departments
- Non Governmental Organizations
- Libraries & Information Centers

Four categories of Professionals

- Teachers & Instructors
- Program Coordinators- (**State & District Level**)
- Trainers –Grassroots level
- Librarians & Information Officers

Four job Specifications

1. Teaching, Research & Extension, Training
2. Training, Material Preparation, & Evaluation.
3. Information Organization, Management & Promotion of Reading
4. Planning , Implementation, & Monitoring

TEACHER TRAINING IN ADULT & LIFELONG LEARNING : Indian Scenario---5

- **Teaching Programs:**

Post Graduate Diploma, M.A/M.Sc. ;M/Phil; Ph.D

- **Training Programs :**

Short duration (3-10 days)

Teacher Training programs:

B.Ed, M.Ed (One optional paper on Adult Education)

TEACHER TRAINING IN ADULT & LIFELONG LEARNING : Indian Scenario---6.

Major Training Methods

- **Cascade** -- Government Organizations
- **Direct (Face to Face)** - Universities & Colleges
- **Participatory** -- Non Governmental Organizations
- **ODL** --- Open Universities and Open Schools

TEACHER TRAINING IN ADULT & LIFELONG LEARNING : Indian Scenario---7.

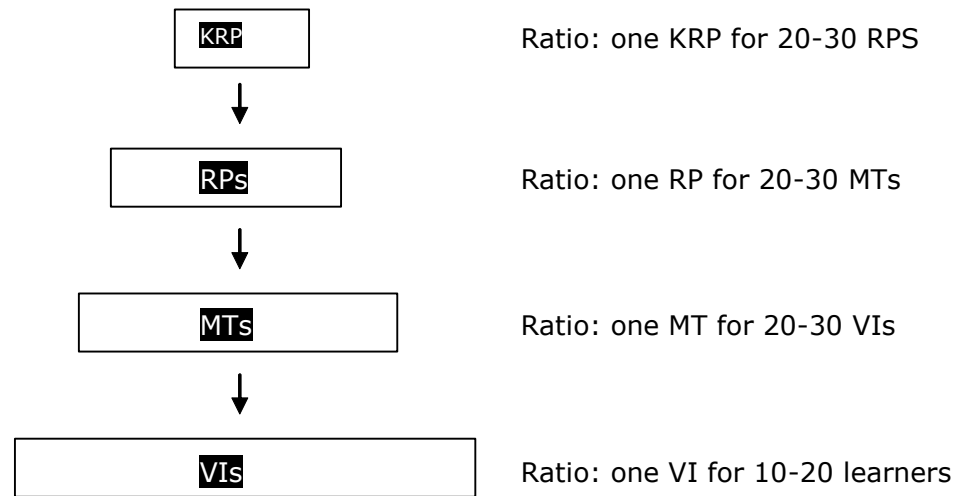

Figure 1. CASCADE APPROACH TO TRAINING



TEACHER TRAINING IN ADULT & LIFELONG LEARNING : Indian Scenario---8.

- **Key Competencies:**
 - Information management
 - Transaction of Basic literacy curriculum
 - Organizational techniques
 - Communication in regional language
 - Monitoring and Evaluation
- 
- 

TEACHER TRAINING IN ADULT & LIFELONG LEARNING : Indian Scenario---9.

Limitations of Current Pre service & In service Training Programs

- Absence of a Regulatory Mechanism for Teacher Training
- Dearth of Competent Master Trainers/Teacher Educators
- Certificate and Diploma programs in Adult Education are 3-12 months duration – contents-superficial & no practical training
- Training packages are of short duration with very little scope for further training.
- Curriculum & Evaluation Methods are not standardized

PALDIN

(Participatory Adult Learning Documentation and Information Network)

What is PALDIN?

An innovative professional development program for the capacity building of intermediary level staff of institutions offering Lifelong Learning programs

TEACHER TRAINING IN ADULT & LIFELONG LEARNING : Indian Scenario---10

PALDIN: Programme Profile

- **Target group:** Adult Educators (Program Managers, Researchers, Documentation Officers, Librarians, Lecturers working in ALADIN Member Institutions)
- **Eligibility:** graduate Degree
- **Medium of Instruction:** English
- **Curriculum Transaction:** Personal Contact, Self-learning through print materials, Online/ Interactive CD support
- **Evaluation:** Participatory, group based, self evaluation (Diary/Journal Writing), Video Documentation
- **Delivery Agents:** ALADIN Member Institutions
- **Total Credits:** 8 (240 study hours)

TEACHER TRAINING IN ADULT & LIFELONG LEARNING

Indian Scenario---11

Aims & Objectives

- Enhancing professional capabilities of participants
- Enabling the participants acquire new knowledge and construct knowledge from personal experiences and local sources
- Enabling the participants acquire new professional skills and sharpen the existing ones .

TEACHER TRAINING IN ADULT & LIFELONG LEARNING

:

Indian Scenario--12

Three Text based courses and a work based project

PALDIN-1

*Participatory Lifelong Learning & Information
Communication Technologies*

PALDIN-2

*Process Documentation, Dissemination &
Net Working*

PALDIN -3

Project work



TEACHER TRAINING IN ADULT & LIFELONG LEARNING : Indian Scenario---13.

PALDIN 1: Contents

- 1. Global, Regional & National scenario on Literacy & Role of Important Adult Learning Organizations -- 4 hrs.
 - 2. Policy on Adult and Lifelong Learning: International and National Perspectives --6 hrs.
 - 3. Discourse on Literacy & Development -- 6 hrs.
 - 4. Sociological & Philosophical background of Adult and Lifelong Learning -- 12 hrs.
 - 5. Teaching-Learning Strategies of Adults and Adult Psychology -- 12 hrs.
 - 6. Preparation of Reading Materials for Neo literate Adults and Creating a Literate Environment -- 20 hrs.
 - 7. Working with Community -- 20 hrs.
 - 8. Participatory Training, Research and Evaluation -- 20 hrs.
 - 9. Role of Information and Communication Technology in Adult & Lifelong Learning. -- 20 hrs.
-

TEACHER TRAINING IN ADULT & LIFELONG LEARNI Indian Scenario---14

PALDIN 2: Process Documentation, Dissemination and Networking -

4 credits or 120 study hrs

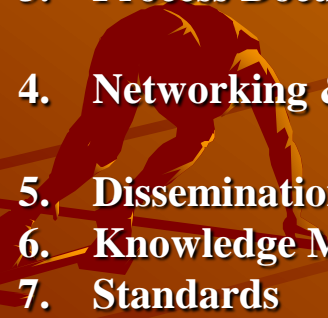
- 
- | | |
|---|---------|
| 1. Human Communication | 10 hrs. |
| 2. Organizational Behaviour | 20 hrs. |
| 3. Process Documentation | 10 hrs. |
| 4. Networking & Adult Learning & ALADIN | 10 hrs |
| 5. Dissemination | 15 hrs. |
| 6. Knowledge Management | 15 hrs. |
| 7. Standards | 15 hrs |
| 8. Managing a Library | 15 hrs |
| 9. Building Library Resources | |
| 10. Communication, Media, system and Strategy | 10 hrs |

TEACHER TRAINING IN ADULT & LIFELONG LEARNING : Indian Scenario--15

- **Issues:**
- No serious thinking on professionalizing training
- Isolated Efforts on a small scale.
- Challenge of covering massive target in cost effective manner
- Poor service conditions of trainers.
- Inadequate number of Master Trainers & absence of research on training.
- Lack of a regulatory body on teacher training

TEACHER TRAINING IN ADULT & LIFELONG LEARNING
: Indian Scenario-16

Thank you

Comments & questions are welcome

Professor S.Y. Shah

Honorary Director

International Institute of Adult And Lifelong Education

New Delhi , India

[E-mail: drsyshah@gmail.com](mailto:drsyshah@gmail.com)

